

biomass energy evolution



Caldie a biomassa

Biomass boilers



eos



uniconfort
Biomass Energy Evolution

TECNOLOGIA INNOVATIVA



Uniconfort opera da 60 anni nel settore della termotecnica avanzata e delle tecnologie per la conversione energetica delle biomasse provenienti dall'agricoltura, dalla lavorazione del legno e dall'industria forestale e del pellet.

Il nostro campo operativo

- Progettazione e produzione di caldaie a biomassa – da 93 kW a 14.000 kW di potenza – per acqua calda, acqua surriscaldata, vapore, olio diatermico, e generatori di aria e gas caldi.
- Impianti a biomassa e impianti di cogenerazione a biomassa “chiavi in mano”.
- Caldaie compatibili con varie tipologie di biomassa (agro-forestali, ad alto contenuto di umidità, pezzatura non omogenea e alto tenore di ceneri).
- Centro Ricerche Interno specializzato nello studio e combustione di biomasse solide convenzionali e non convenzionali.
- Consulenza per ottenimento Incentivi statali (Certificati Bianchi e Verdi).

Diamo risposta ad ogni vostra esigenza. Il nostro Centro ricerca e sviluppo è in grado di progettare impianti personalizzati e completi: dal serbatoio per il combustibile al camino.

E non vi lasciamo mai soli. Le nostre squadre lavorano in ogni parte del mondo (siamo tra i primi tre produttori a livello mondiale di impianti a biomassa solida) e siamo in grado di seguirvi anche dopo l'avvio dell'impianto, con il nostro team di assistenza tecnica, che opera anche con un efficiente sistema di **teleassistenza**, o fornendo pacchetti di **formazione** ai vostri tecnici.

Vi facciamo risparmiare. Non dovrete più acquistare combustibili fossili, che costano il doppio delle biomasse legnose ed i cui prezzi continuano ad aumentare. Un risparmio che vi permetterà di ammortizzare in poco tempo il costo degli impianti e che presto si traduce in taglio dei costi.

AIUTIAMO L'AMBIENTE



Siamo in grado di trasformare i vostri scarti di lavorazione in combustibile. I residui si trasformano così da costo a risorsa.

I nostri impianti sono ad alta efficienza. Questo significa migliori prestazioni, minori consumi e quindi minori costi.

E vi facciamo risparmiare anche sul personale: i nostri impianti sono, infatti, ad alto livello di automazione.

Insieme a voi aiutiamo l'ambiente. Fino ad oggi i nostri impianti hanno risparmiato all'ambiente emissioni di CO₂ equivalenti a 60 milioni di automobili che fanno il giro del mondo. Questo perché produciamo energia a CO₂ neutrale (CO₂ evitata rispetto all'uso di combustibili fossili). Inoltre, grazie alla continua ricerca e sperimentazione che mira all'ottimizzazione della combustione, i nostri impianti abbattano drasticamente le emissioni, ampiamente al di sotto dei limiti stabiliti dalle normative europee ed internazionali.



MIGLIORI PRESTAZIONI



TECHNOLOGY

INNOVATIVE For 60 years Uniconfort has operated in the sector of advanced thermotechnology and technologies for converting energy from biomass originating from agriculture, wood waste and from the forestry and pellet industries.

Our field of operation

- Design and production of biomass boilers – from 93 kW to 14,000 kW of power – for hot water, heated water, steam, diathermic oil and hot air and gas generators.
- “Turnkey” biomass systems and biomass co-generation systems.
- Boilers compatible with various types of biomass (agro-forestry with high humidity levels, non-homogenous sizes and high ash content).
- **Internal Research Centre** specialised in the study and combustion of conventional and unconventional solid biomass.
- Consultancy for achieving State Incentives (White and Green Certificates).



BETTER PERFORMANCE

We meet all your needs. Our research and development Centre is able to design customised and complete systems: from the fuel tank to the flue.

And you will never be alone. Our teams work all over the world (we are among the first three manufacturers of solid biomass systems in the world) and we are also able to follow-up after your system is operational, with our technical support team which also operates with an efficient **teleassistance service**, or by supplying your technicians with **training packages**.

We help you save money. You no longer need to buy fossil fuels which are double the price of wood biomass and their cost continues to increase. A saving which will allow you to amortise the cost of the systems in a short time and which will quickly mean lower operating costs.

We are able to transform your working waste into fuel. In this way waste is transformed from cost to resource.

Our systems are highly efficient. This means better performance, lower consumption and therefore lower costs.

And you also save on personnel: in fact our systems are highly automated.

Together we can help the environment. Up to today our systems have saved the environment from CO₂ emissions equivalent to 60 million automobiles travelling around the world. This is because we produce CO₂ neutral energy (CO₂ avoided compared with using fossil fuels). Furthermore, thanks to continuing research and development aimed at optimisation combustion, our systems drastically lower emissions, well below the limits established by European and International standards.

WE HELP THE ENVIRONMENT



EOS PUNTI DI FORZA



EFFICIENZA CON L'ELEVATA SUPERFICIE DI SCAMBIO DELLO SCAMBIATORE E LA BASSA TEMPERATURA DEI FUMI, EOS GARANTISCE RENDIMENTI ELEVATI CHE POSSONO ARRIVARE FINO AL 93%.

EFFICIENCY WITH THE HIGH EXCHANGE SURFACE OF THE EXCHANGER AND THE LOW SMOKE TEMPERATURE, EOS GUARANTEES HIGH YIELDS WHICH CAN REACH UP TO 93%.



PULIZIA AUTOMATICA IL SISTEMA DI PULIZIA AUTOMATICA GARANTISCE ELEVATI RENDIMENTI ED UNA DRastica RIDUZIONE DEL FERMO MACCHINA DOVUTO ESCLUSIVAMENTE ALLE MANUTENZIONI ORDINARIE DELL'IMPIANTO.

AUTOMATIC CLEANING THE AUTOMATIC CLEANING SYSTEM GUARANTEES HIGH YIELD AND A DRastic REDUCTION IN MACHINE DOWNTIME ONLY REQUIRED FOR ORDINARY SYSTEM MAINTENANCE.



ACCENSIONE AUTOMATICA CONSENTE UNA MIGLIORE PROGRAMMAZIONE DELLO START & STOP DELL'IMPIANTO OTTIMIZZANDO L'INGRESSO DELLA BIOMASSA E LE EMISSIONI AL CAMINO.

AUTOMATIC SWITCH-ON ALLOWS BETTER SYSTEM START & STOP PROGRAMMING OPTIMISING BIOMASS INPUT AND EMISSIONS TO THE FLUE.



uniconfort
Biomass Energy Evolution



PRESSIONE EOS CONSENTE DI LAVORARE CON PRESSIONI DOPPIE RISPETTO A QUELLE DELLA SUA CATEGORIA (FINO A 4 BAR). PUÒ LAVORARE CON DIFFERENZE DI TEMPERATURA INGRESSO-USCITA PIÙ ALTE CHE CONSENTONO DI INSTALLARE POMPE CON BASSE PORTATE. IL TUTTO SI TRADUCE IN CONSUMI ENERGETICI INFERIORI.

PRESSURE EOS PERMITS WORKING AT DOUBLE PRESSURE COMPARED WITH THOSE OF ITS CATEGORY (UP TO 4 BAR). IT CAN WORK WITH HIGHER DIFFERENCES IN INPUT-OUTPUT TEMPERATURE WHICH ALLOW LOW FLOW RATE PUMPS TO BE INSTALLED. ALL THIS MEANS LOWER ENERGY CONSUMPTION.



SISTEMA DI COMBUSTIONE CON IL NUOVO SISTEMA DI COMBUSTIONE EOS OFFRE MASSIMA FLESSIBILITÀ DI BIOMASSA IN INGRESSO.

COMBUSTION SYSTEM WITH ITS NEW COMBUSTION SYSTEM EOS OFFERS THE HIGHEST FLEXIBILITY OF INCOMING BIOMASS.



STRENGTHS

I combustibili per Eos

75%

EOS è progettata per la combustione di biomasse con contenuto di umidità fino al 75% su base secca e particolarmente adatta a biomasse agricole con elevato tenore di ceneri.

EOS ha una griglia di combustione ibrida a due zone: la prima parte fissa e la seconda mobile per una combustione flessibile ed adatta ai diversi tipi di combustibile introdotto.

EOS è adatta alla produzione di: Acqua Calda, Acqua Surriscaldata, Vapore.

Potenza di EOS: da 170 a 5.800 kW.

Fuels for Eos

EOS is designed for burning biomass with a humidity levels up to 75% on a dry base and particularly suited to agricultural biomasses with high ash content.

EOS has a two-part hybrid combustion grate: the first part is fixed and the second is mobile for flexible combustion and suited to different types of loaded fuel.

EOS is suited to the production of Hot Water, Heated Water and Steam.

EOS power: from 170 to 5,800 kW.



cippato secco
dry wood chips



cippato umido
wet wood chips



ramaglie
twigs



pellet
pellets



bricchetti
briquettes



segatura
sawdust



uniconfort
Biomass Energy Evolution

SISTEMA CIPPATO WOOD CHIP SYSTEM

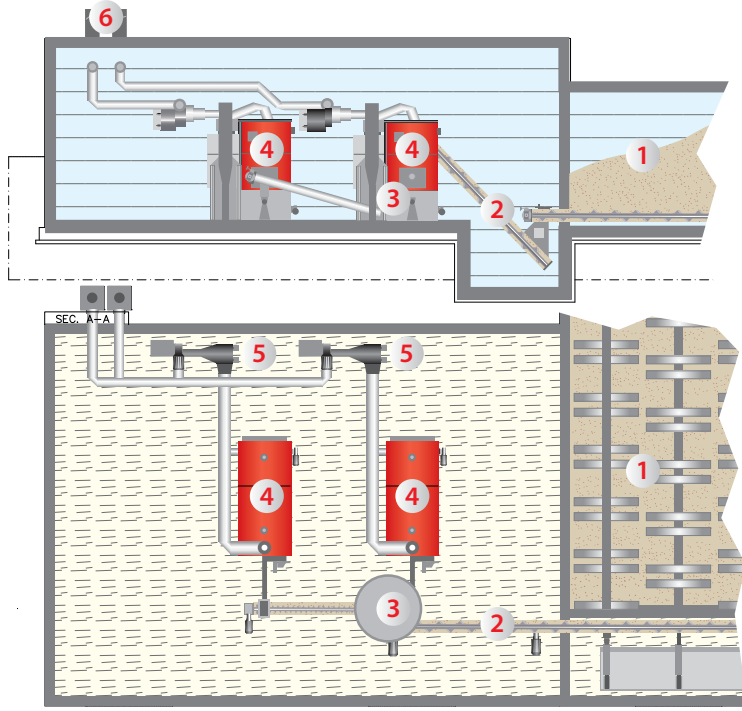

1. SILO PER CIPPATO (SISTEMA WALKING FLOOR)
WOOD CHIP STORE (WALKING FLOOR SYSTEM)
2. COCLEA SECONDARIA
SECONDARY SCREW
3. ALIMENTATORE CILINDRICO
CYLINDRICAL FEEDER
4. CALDAIA
BOILER
5. MULTICLONE
MULTICYCLONE
6. CAMINO
CHIMNEY

SISTEMA PELLETTI PELLET SYSTEM

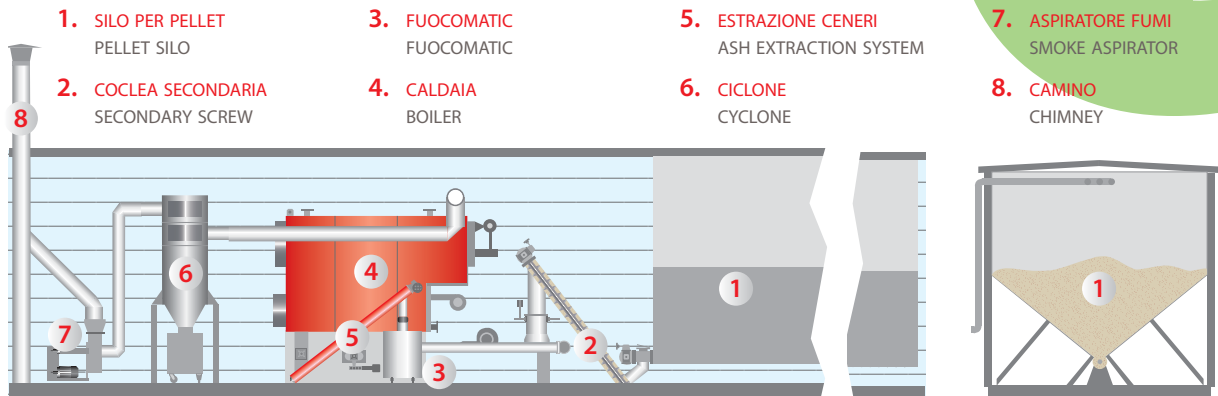

1. SILO PER PELLETTI
PELLET SILO
2. COCLEA SECONDARIA
SECONDARY SCREW
3. FUOCOMATIC
FUOCOMATIC
4. CALDAIA
BOILER
5. ESTRAZIONE CENERI
ASH EXTRACTION SYSTEM
6. CICLONE
CYCLONE
7. ASPIRATORE FUMI
SMOKE ASPIRATOR
8. CAMINO
CHIMNEY

SISTEMA CONTENITORE E SKID CONTAINER AND SKID SYSTEM

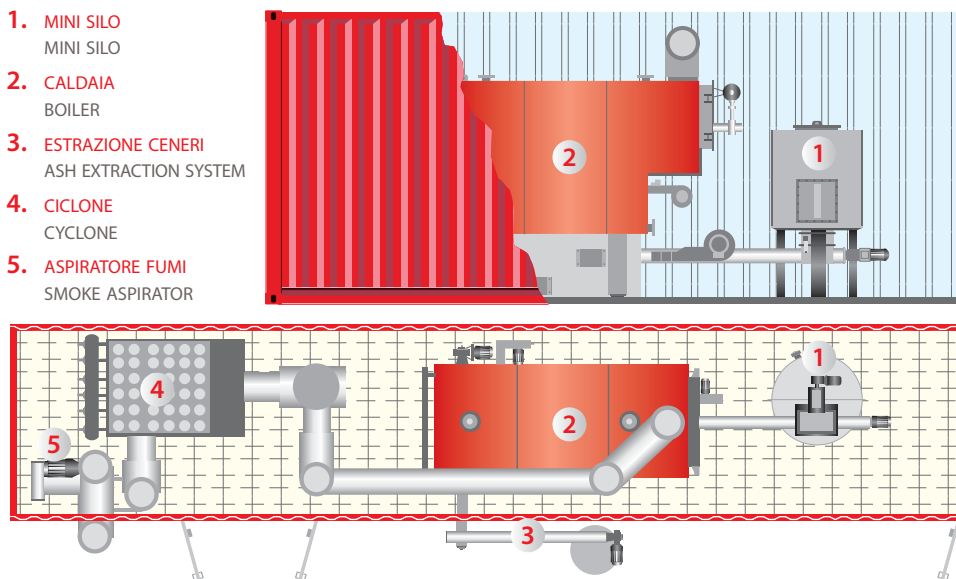

1. MINI SILO
MINI SILO
2. CALDAIA
BOILER
3. ESTRAZIONE CENERI
ASH EXTRACTION SYSTEM
4. CICLONE
CYCLONE
5. ASPIRATORE FUMI
SMOKE ASPIRATOR

EOS: alta efficienza, alta flessibilità

EOS (Energy Of State) è una famiglia di caldaie Uniconfort di potenza variabile dai 170 ai 5800 kW, caratterizzata da alta efficienza, zero manutenzione (è autopulente), accensione automatica e alta pressione di esercizio.

EOS: high efficiency, great flexibility

EOS (Energy of State) is a series of Uniconfort boilers, with powers varying from 170 to 5800 kW, characterised by high efficiency, zero maintenance (it's self-cleaning), automatic switch-on and high operating pressure.

SCHEMA FUNZIONALE FUNCTIONAL DIAGRAM

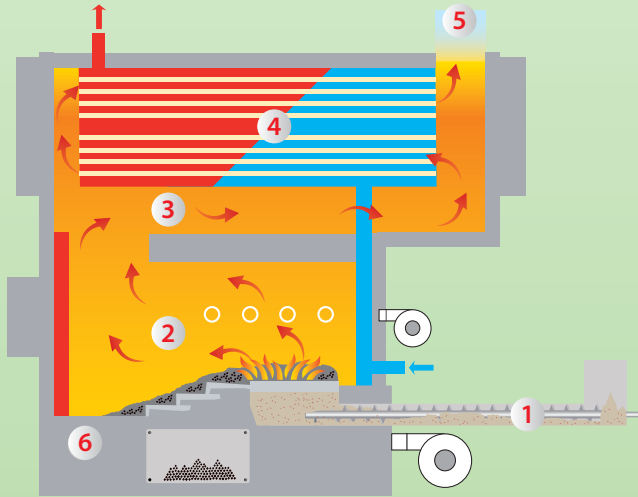

1. coclea di alimentazione
screw
2. camera di combustione
combustion chamber
3. camera di post-combustione
post-combustion chamber
4. scambiatore di calore
heat exchanger
5. camino
chimney
6. estrazione ceneri
ash extraction

DATI TECNICI MISURE TECHNICAL DATA AND DIMENSIONS

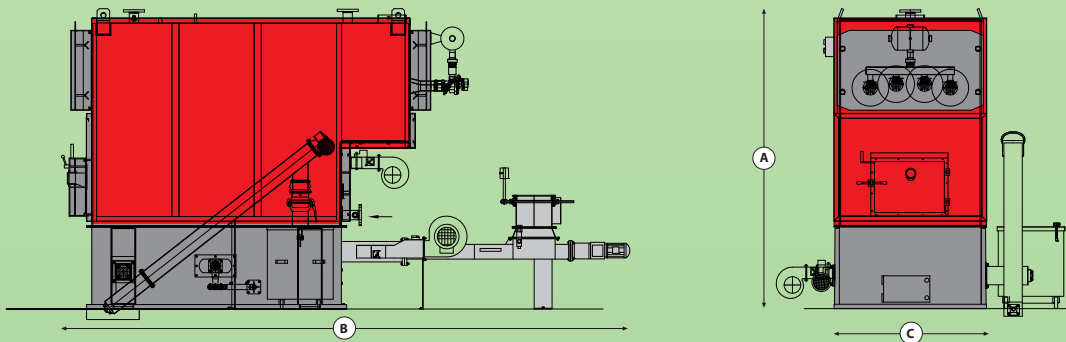

MODELLO	MODEL	15	20	25	30	35	45	50	60	65	70	80	90	100	120	140	150	160	200	220	250	270	280	300	350	360	380	400	500	
Potenza resa Power Yield	Kcal/h (x 1000) kW	150 170	200 230	250 290	300 340	350 400	450 523	500 580	600 690	650 750	700 810	800 930	900 1000	1000 1150	1200 1390	1400 1620	1500 1700	1600 1860	2000 2300	2200 2550	2500 2900	2700 3100	2800 3250	3000 3450	3500 4050	3600 4100	3800 4400	4000 4650	5000 5800	
Altezza massima* Maximum height*	A - mm	2190	2190	2190	2860	2860	2860	3150	3150	3150	3150	3150	3150	3300	3300	3300	4400	4400	4400	4600	4600	4600	4600	4600	4600	4600	4900	4900	4900	
Lunghezza massima* Maximum length*	B - mm	4050	4050	4050	5400	5400	5400	5400	5400	5400	5400	5400	5400	6700	6700	6700	7300	7300	7300	7700	7700	7700	9100	9100	9100	9100	9500	9500	9500	
Larghezza massima* Maximum width*	C - mm	1000	1000	1000	1450	1450	1450	1450	1450	1450	1850	1850	1850	2120	2120	2120	2120	2120	2120	2120	2120	2120	2120	2120	2120	2120	2120	2300	2300	2300

* Le misure possono subire variazioni anche sulla base di specifiche esigenze - Measurements may undergo variations also according to specific requirements

APPLICAZIONI DI EOS EOS APPLICATIONS APPLICAZIONI DI EOS EOS APPLICATIONS APPLICAZIONI

EOS SU SKID EOS ON SKID



- L'intero impianto – per riscaldamento, illuminazione e raffrescamento – è assemblato su piattaforma
- CATENA DI SUPERMERCATI
- REGNO UNITO
- The whole system – for heating, lightning and cooling – is assembled on a platform
- CHAIN OF SUPERMARKETS
- UNITED KINGDOM



EOS PER RETI DI TELERISCALDAMENTO EOS FOR DISTRICT HEATING NETWORKS



- A servizio di edifici pubblici e privati
- COMUNE DI ROSÀ - VICENZA
- ITALIA
- At the service of public and private buildings
- MUNICIPALITY OF ROSÀ - VICENZA
- ITALY

EOS IN CONTAINER EOS IN CONTAINER



- Sistema integrato composto da due container: uno adibito a centrale termica l'altro allo stoccaggio del combustibile
- CENTRO SPORTIVO
- CHILE
- Integrated system formed by two containers: one used as a thermal power station and the other one for storing fuel
- SPORTING CENTRE
- CHILE



**EOS PER RISCALDARE
ALBERGHI E AGRITURISMI**

EOS FOR HEATING HOTELS AND HOLIDAY FARMS



- Energia verde per camere, centro benessere e ristorante in Lombardia
- AGRITURISMO
- ITALIA
- Green energy for rooms, Spa and restaurant in Lombardia (Italy)
- HOLIDAY FARM
- ITALY

EOS PER IL FLOROVIVAISMO

EOS FOR GARDENING NURSERIES



- Energia termica per serre e vivai
- VIVAIO IN VENETO
- ITALIA
- Thermal energy for glasshouses and garden centres
- NURSERY IN VENETO
- ITALY



**EOS PER LA STERILIZZAZIONE
DI CELLE DELLE FUNGAIE**

EOS FOR STERILISING MUSHROOM FARMS



- Energia termica per processo produttivo
- FUNGAIA
- IRLANDA
- Thermal energy for a production process
- MUSHROOM FARM
- IRELAND

UNICONFORT BIOMASS BOILERS

Italian Technology at Competitive Prices

A Range of European High Efficiency Biomass Boilers

Now Available in New Zealand

AUTOMATIC Ignition, AUTOMATIC Fuel Feed,
AUTOMATIC Ash Extraction, AUTOMATIC Flue Gas Cleaning.

LOW EFFORT, NO MESS ENERGY

EFFICIENCY

Biomass System operating on zero balance CO₂ when compared to fossil fuels
High efficiency with low NO_x and particulate matter.
Efficiencies which can reach 93%

FUELS

Wood Pallet, Wood Chip and various other biomass fuels
Designed to ably operate with high moisture content up to 75% on a dry matter basis
(however the lower the moisture content the higher the thermal output)
Ash can used as a composting agent

RANGE

Wide range of boilers form 199kW to 25MW
200kw systems can be operated from inside a standard container

EXPERIENCE

60 years of experience in converting Biomass into Energy

We will help you save money and protect the environment.

Taylors Manufacturing Ltd, Phone 03 389 7149, Julian@taymac.co.nz,
www.taymac.co.nz

Taymac

Taylors Manufacturing Limited
PRESENTS



TECHNOLOGY FOR BIOMASS ENERGY



from 199 kW
to 25 MW



Taylors Manufacturing Ltd, Phone 03 389 7149, Julian@taymac.co.nz, www.taymac.co.nz

OUR PLANTS ALL OVER THE WORLD



Taylors manufacturing Ltd
trading as TAYMAC
19 Taurus Place, Bromley
P.O. Box 19 757, Woolston
Christchurch, New Zealand
Ph +64 (0)3 389 7149
Fx +64 (0)3 389 7078
sales@taymac.co.nz



uniconfort.com